

***punt***

Art, craft & design

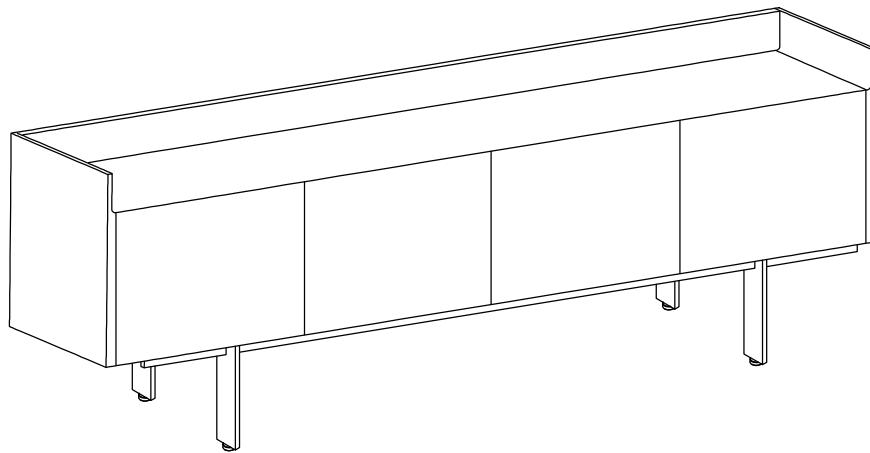

**STOCKHOLM**

ASSEMBLY INSTRUCTIONS

## FITTINGS STH 4 MOD / 5 MOD HERRAJES

**A**

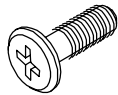

78928  
4 MOD - 18 UDS  
5 MOD - 20 UDS

M4 x 30

**B**

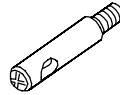

98825 - silver. plata  
4 MOD - 18 UDS  
5 MOD - 19 UDS

**C**



70666 - silver. plata  
71246 - dark. grafito  
4 MOD - 22 UDS  
5 MOD - 23 UDS

**D<sub>a</sub>**



M6x8

98186 - silver. plata  
4 MOD - 22 UDS  
5 MOD - 23 UDS

**D<sub>b</sub>**



M6x6

71250 - dark. grafito  
4 MOD - 22 UDS  
5 MOD - 23 UDS

**E**



Nº4  
98599 -1uds

**F**

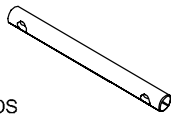

70300  
4 MOD - 4 UDS  
5 MOD - 4 UDS

**G**



4 MOD - 4 UDS  
5 MOD - 5 UDS

**H**

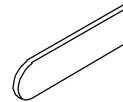

4 MOD - 8 UDS  
5 MOD - 10 UDS

**I**



98619  
4 MOD - 4 UDS  
5 MOD - 4 UDS

M6X25

**J**



71209 M6 D16  
4 MOD - 4 UDS  
5 MOD - 4 UDS

**K**



98911 M6  
4 MOD - 4 UDS  
5 MOD - 4 UDS

**L**

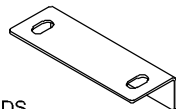

4 MOD - 2 UDS  
5 MOD - 2 UDS

**M**

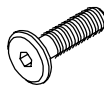

70044 M6X15  
4 MOD - 2 UDS  
5 MOD - 2 UDS

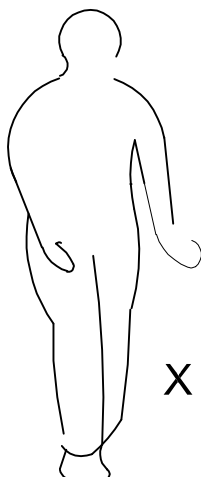

X 3

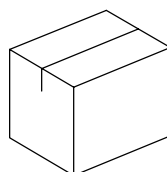

X 3

# STOCKHOLM

BY MARIO RUIZ, 2015

*punt*

SOLO SI LLEVA CAJONES, SI NO IR A PASO 1  
ONLY IF IT HAS DRAWERS, IF NOT GO TO STEP 1

## 1A REMOVE DRAWERS. QUITAR CAJONES.

### 1.1A MOVE EYELASHES IN. MOVER PESTAÑAS HACIA DENTRO.

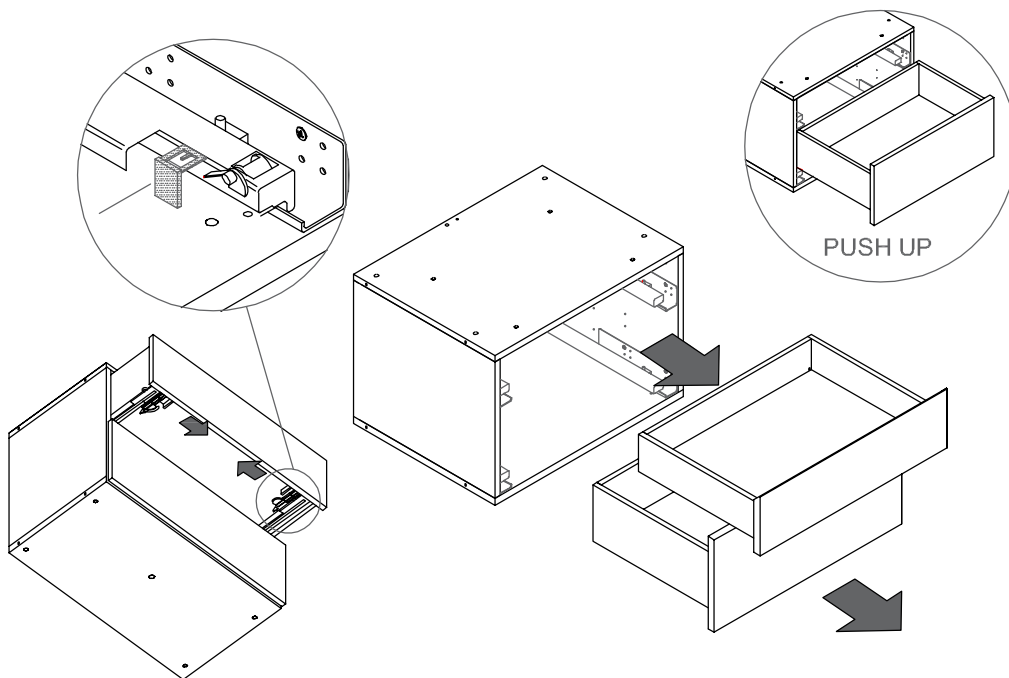

### 1.2A REMOVE DRAWERS. SACAR CAJONES.

# STOCKHOLM

BY MARIO RUIZ, 2015

*punt*

## 1 POSITION PLUNGER. POSICIONAR ÉMBOLO.

**C**  8 uds

70666 - silver. plata  
71246 - dark. grafito

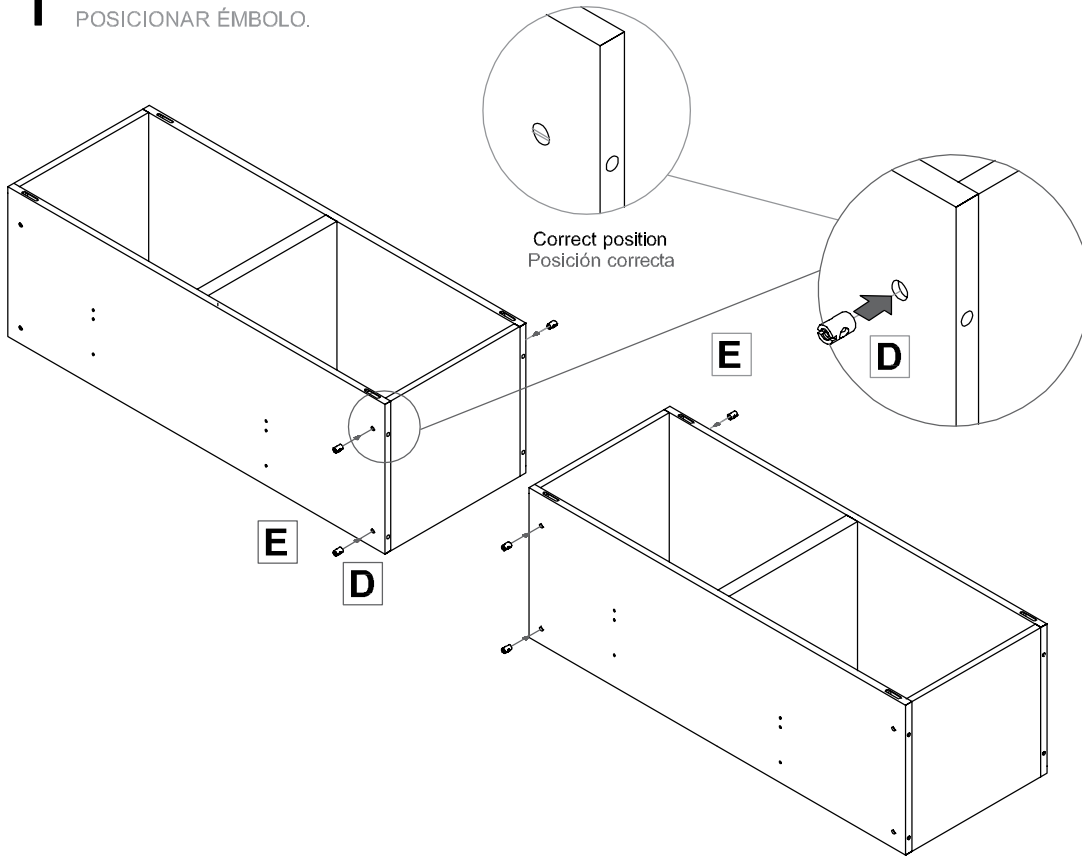

## 2 GET TOGETHER MODULES AND LOCK. JUNTAR MÓDULOS Y BLOQUEAR.

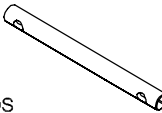
**F**   
70300  
4 MOD - 4 UDS  
5 MOD - 4 UDS

**D**  8 uds

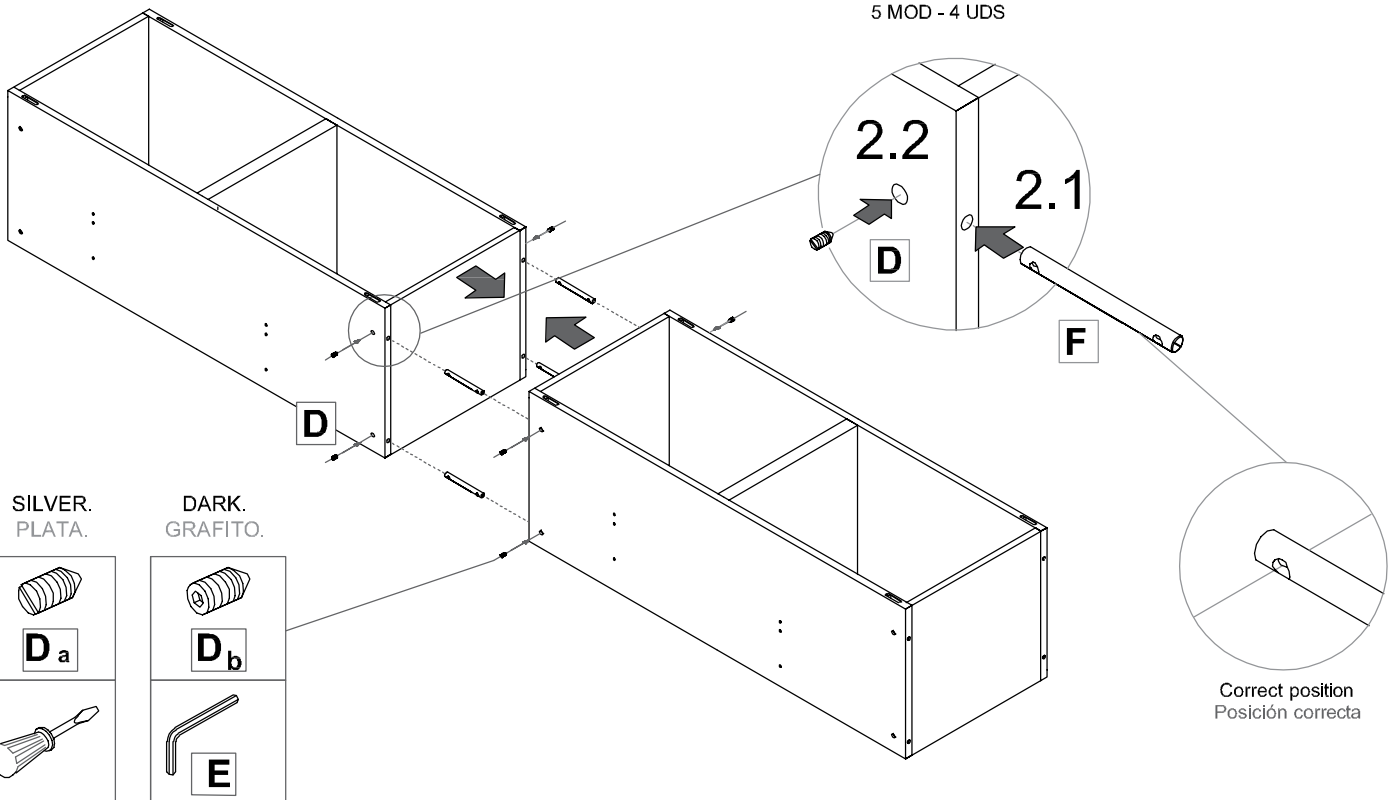

# STOCKHOLM

BY MARIO RUIZ, 2015

**punt**

**3** PLACE PIUNGER AND SCREW BOLT.  
COLOCAR ÉMBOLO Y ATORNILLAR PERNO.

**B**

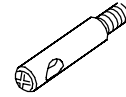

98825 - silver. plata  
4 MOD - 4 UDS  
5 MOD - 5 UDS

**C**



70666 - silver. plata  
71246 - dark. grafito  
4 MOD - 4 UDS  
5 MOD - 5 UDS

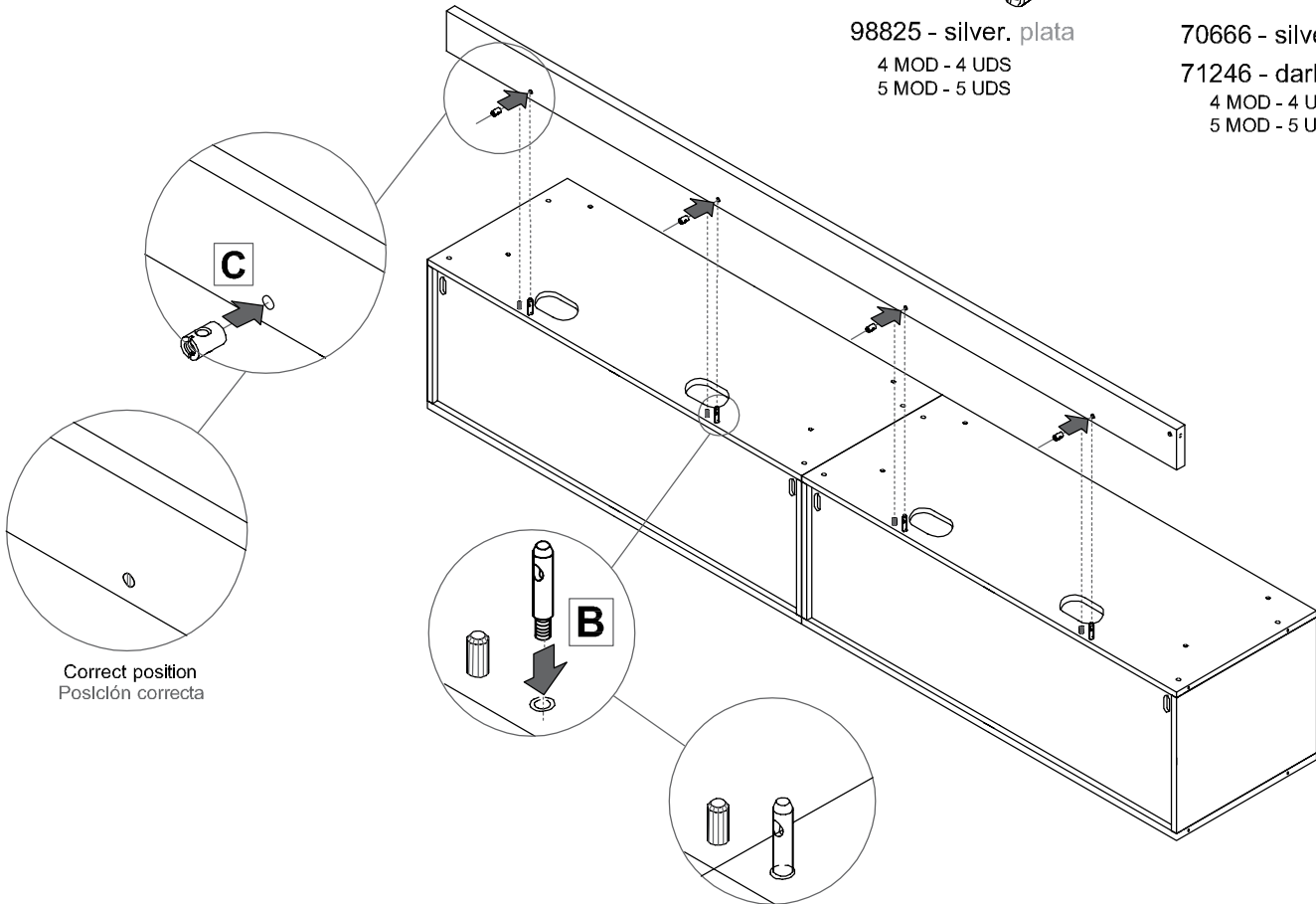

Correct position  
Posición correcta

Correct position  
Posición correcta

**4** PLACE AND LOCK.  
COLOCAR Y BLOQUEAR.

**D**



4 MOD - 22 UDS  
5 MOD - 23 UDS

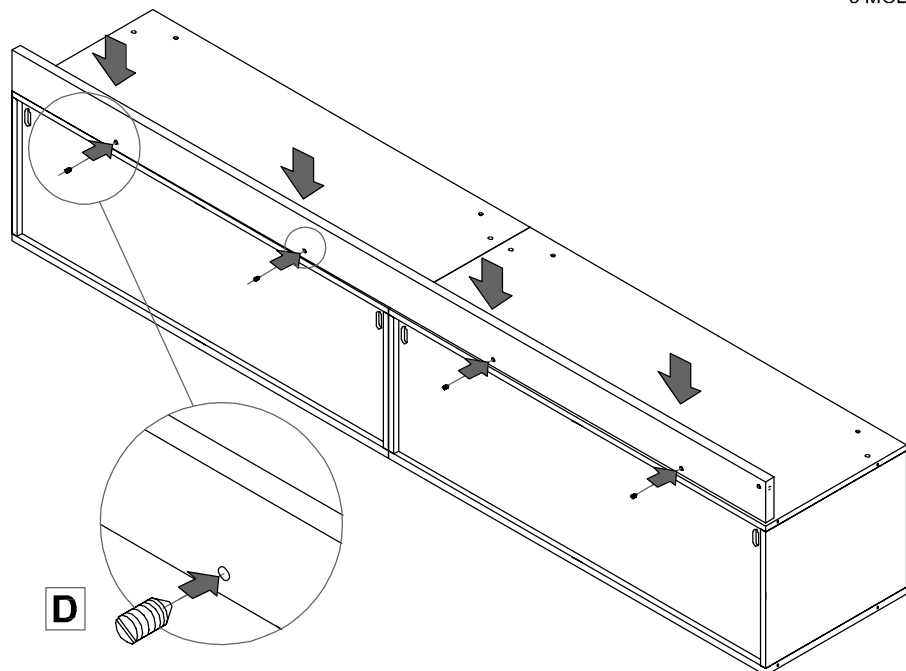

**4.1** LOCK POWDER.  
BLOQUEAR COPETE.

SILVER.  
PLATA.

DARK.  
GRAFITO.

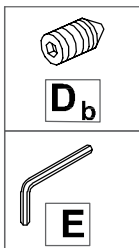
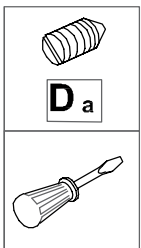

# STOCKHOLM

BY MARIO RUIZ, 2015

**punt**

## 5 POSITION PLUNGER. POSICIONAR ÉMBOLO.



70666 - silver. plata  
71246 - dark. grafito  
4 MOD - 10 UDS  
5 MOD - 10 UDS

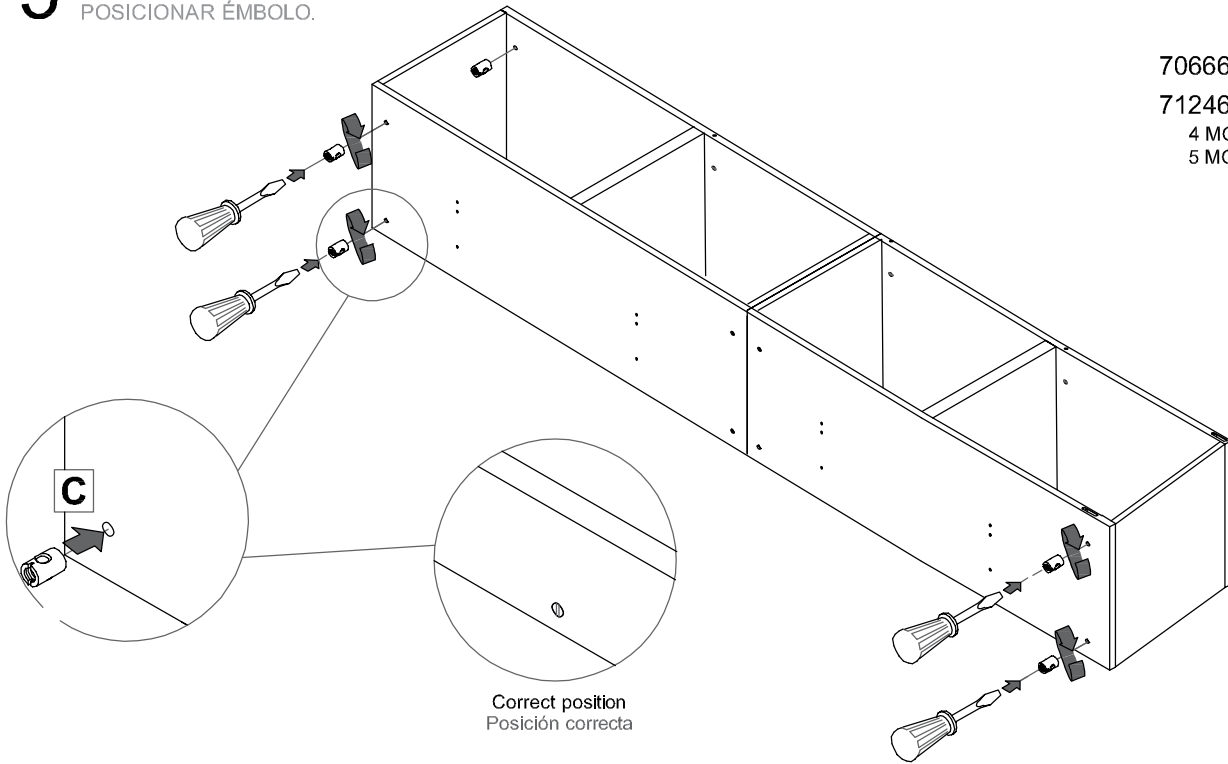

## 5.1 ROTATE MODULE AND POSITION PLUNGER. GIRAR MÓDULO Y POSICIONAR ÉMBOLO.

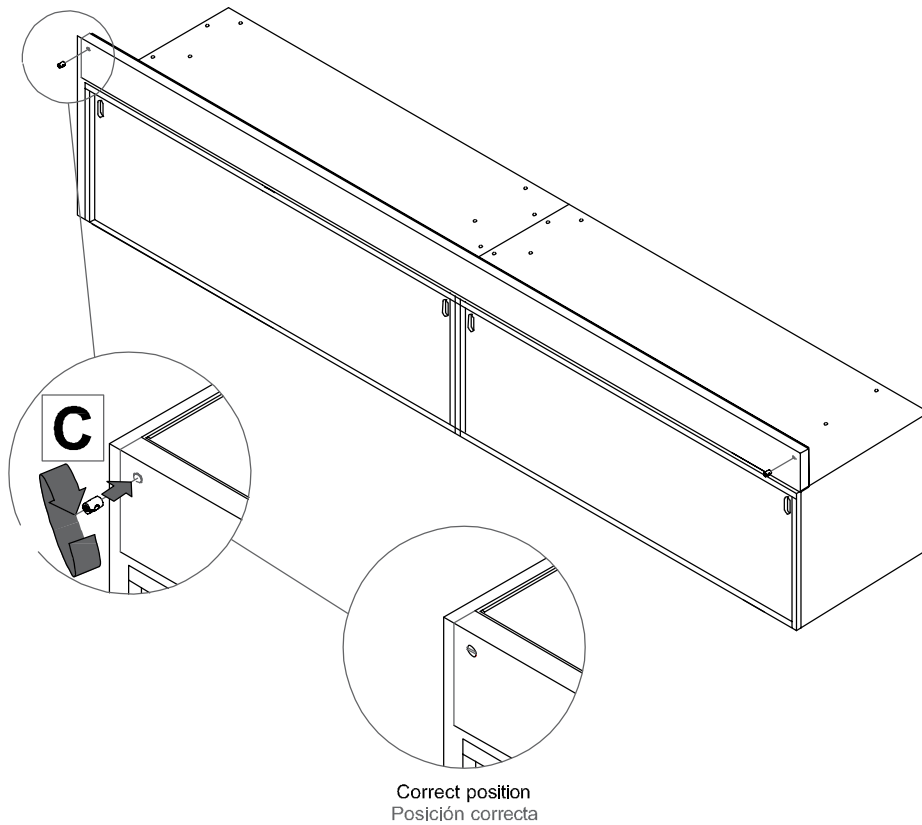

# STOCKHOLM

BY MARIO RUIZ, 2015

*punt*

## 6 SCREW AND LOCK. ATORNILLAR Y BLOQUEAR.

**B**

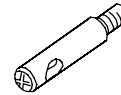

**D<sub>a</sub>**



98825 - silver. plata  
4 MOD - 10 UDS  
5 MOD - 10 UDS

98186 - silver. plata  
71250 - dark. grafito  
4 MOD - 22 UDS  
5 MOD - 23 UDS

### 6.1 SCREW ATORNILLAR

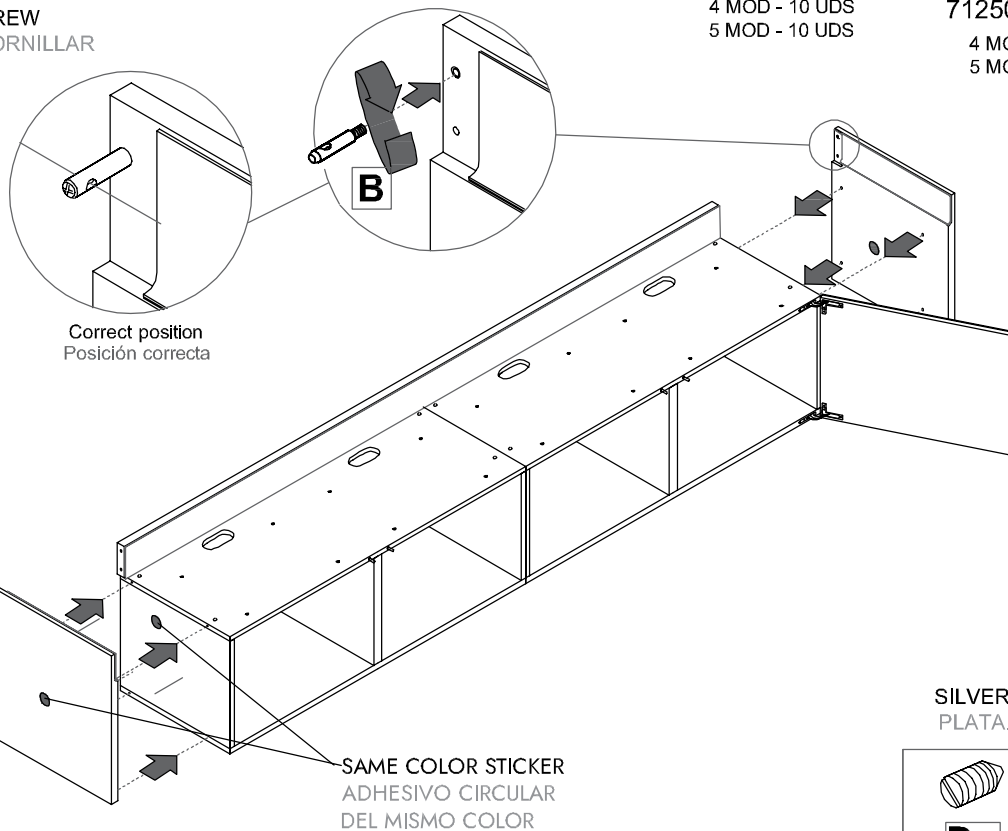

SILVER.  
PLATA.

DARK.  
GRAFITO.

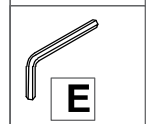
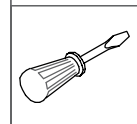
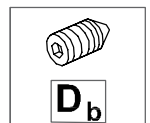
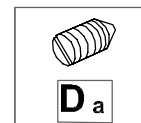

### 6.2 BLOCK POPTOP AND SIDES. BLOQUEAR COPETE Y COSTADOS.

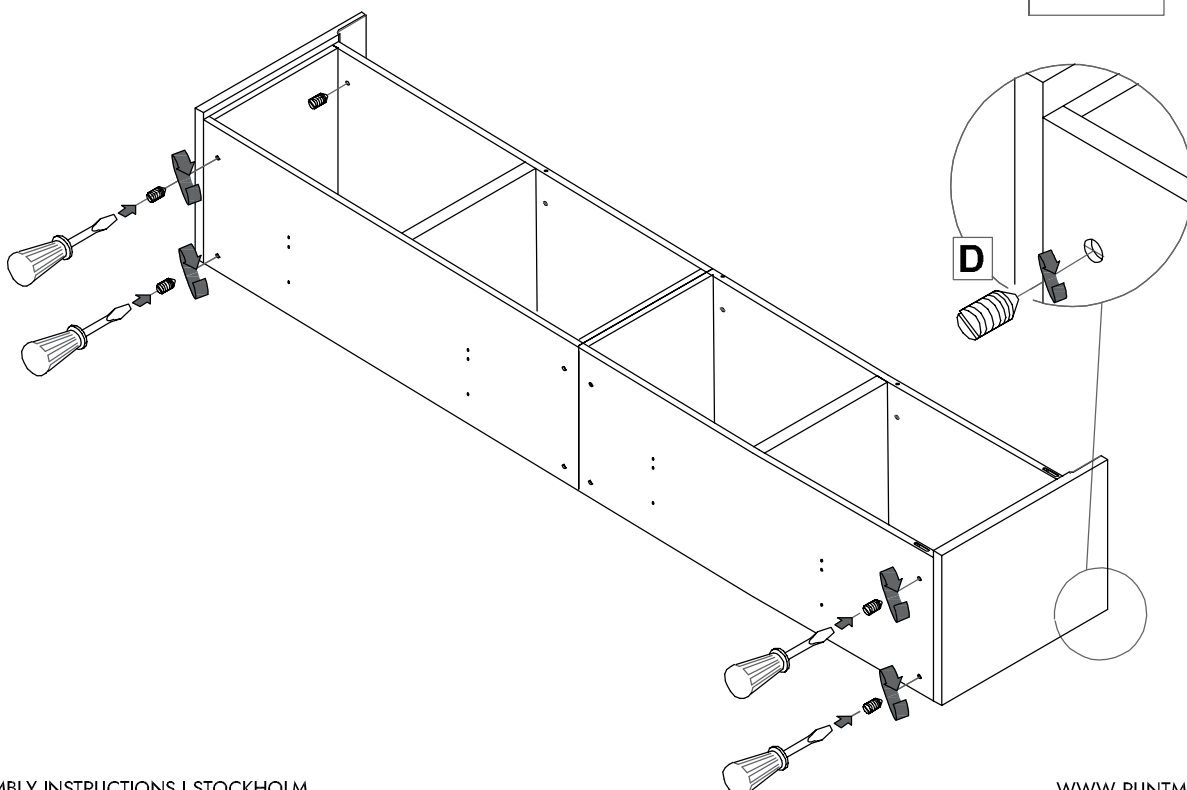

# STOCKHOLM

BY MARIO RUIZ, 2015

*punt*

## COUNTERTOP ASSEMBLY. MONTAJE DE ENCIMERA.

**7** POSITION COUNTERTOP AND SCREW.  
POSICIONAR ENCIMERA Y ATORNILLAR.

**A**

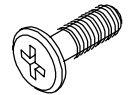

78928

4 MOD - 8 UDS  
5 MOD - 12 UDS

M4 x 30

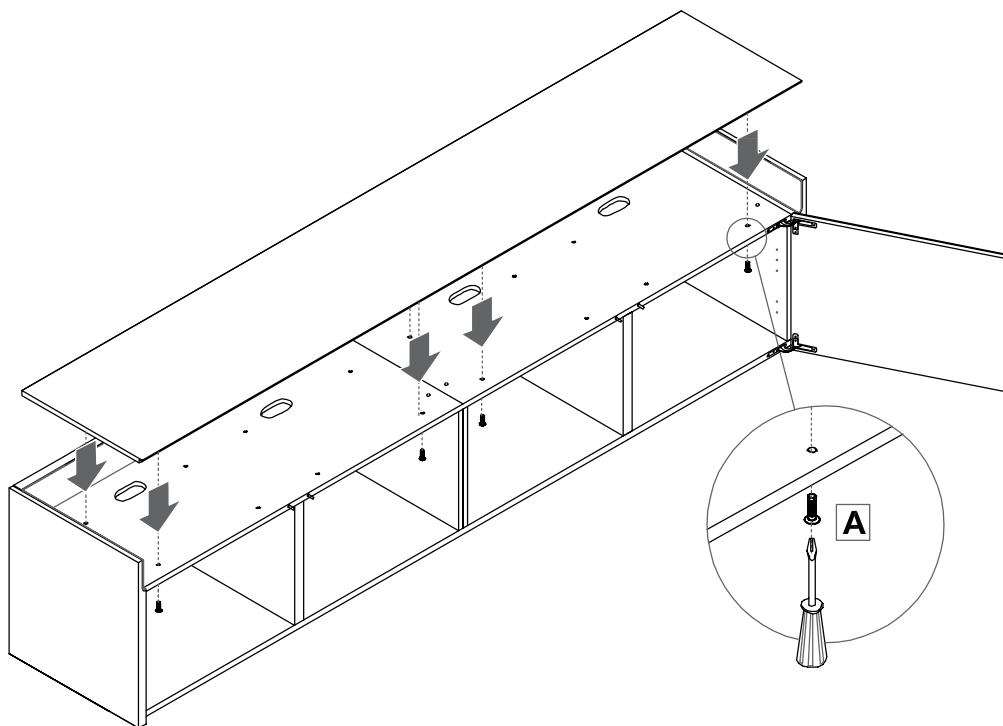



# STOCKHOLM

BY MARIO RUIZ, 2015

*punt*

## PLINTH ASSEMBLY

## MONTAJE DE ZÓCALO

**8** PLACE CROSS BAR ON THE LEGS.  
POSICIONAR LARGUERO EN LAS PATAS.

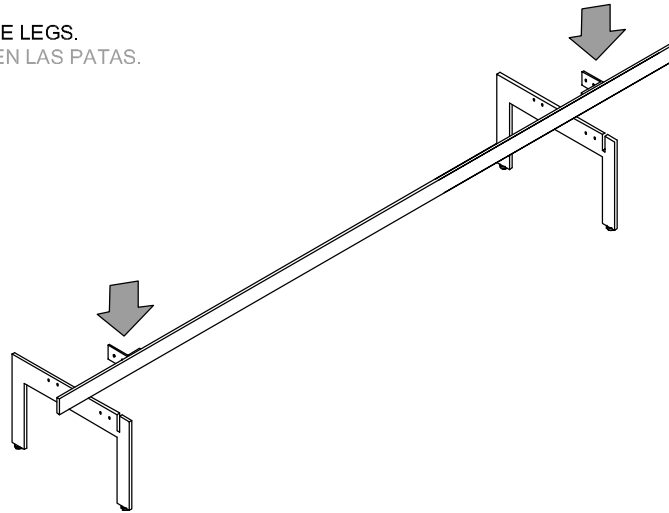

**9** SCREW CROSS BAR TO THE LEGS.  
ATORNILLAR LARGUERO A LAS PATAS.

**I**

98619  
4 MOD - 4 UDS  
5 MOD - 4 UDS

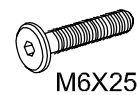

M6X25

**J**

71209  
4 MOD - 4 UDS  
5 MOD - 4 UDS



M6 D16

**K**

98911 M6  
4 MOD - 4 UDS  
5 MOD - 4 UDS



**E**

98599 -1uds  
Nº4

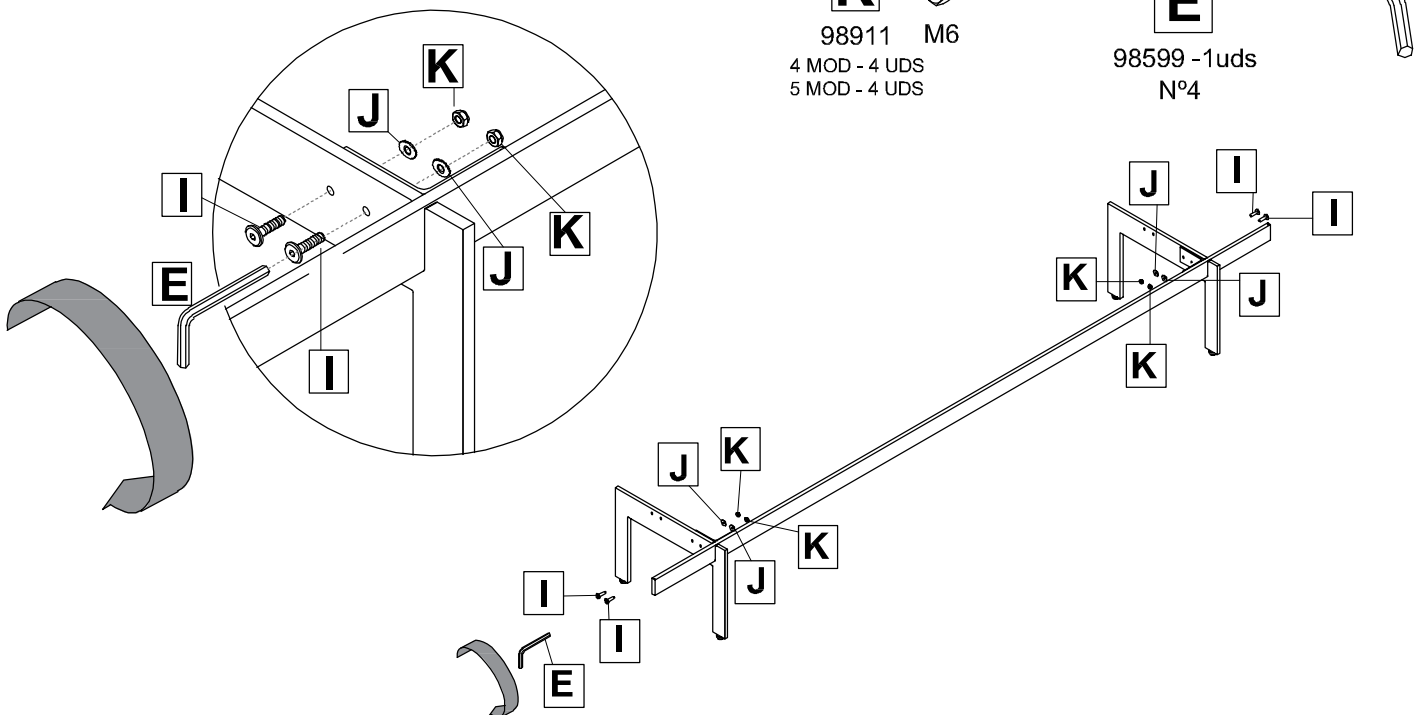
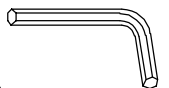

# STOCKHOLM

BY MARIO RUIZ, 2015

*punt*

## 10 SCREW PLATES TO THE LEGS. ATORNILLAR PLETINAS A LAS PATAS.

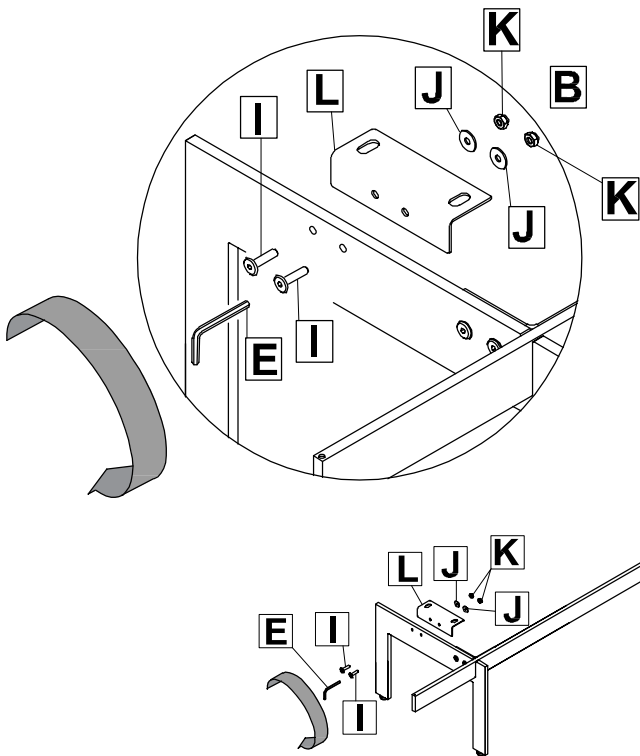

**I**

98619

4 MOD - 4 UDS  
5 MOD - 4 UDS

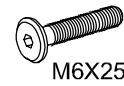

M6X25

**J**

71209

4 MOD - 4 UDS  
5 MOD - 4 UDS



M6 D16

**K**

98911

4 MOD - 4 UDS  
5 MOD - 4 UDS



M6

**E**

98599 -1uds  
Nº4

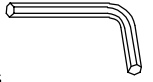

**L**

4 MOD - 2 UDS  
5 MOD - 2 UDS

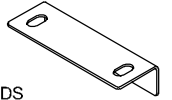

## 11 PLACE PLINTH IN THE FINAL POSITION AND ADJUST IT. SITUAR ZOCALO EN LA POSICIÓN FINAL Y NIVELARLO.

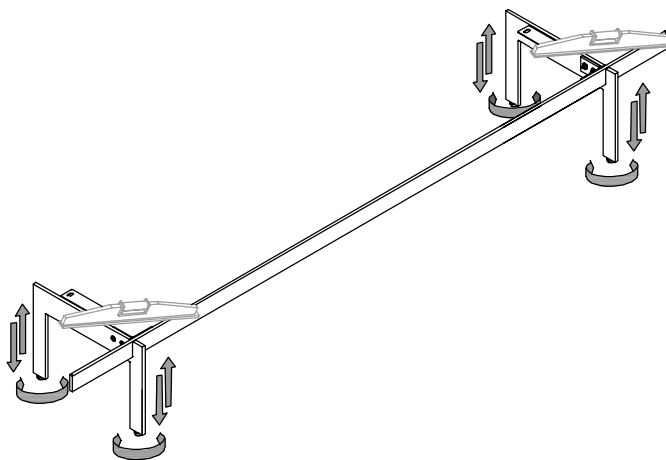

ALL SIDEBARDS ARE ASSEMBLED AND ADJUSTED AT THE FACTORY, BUT IT IS IMPORTANT TO REPEAT THE PROCESS AT THE FINAL LOCATION.

TODOS LOS APARADORES SE MONTAN Y REGULAN EN FÁBRICA, PERO ES IMPORTANTE REPETIR EL PROCESO EN EL LUGAR FINAL.

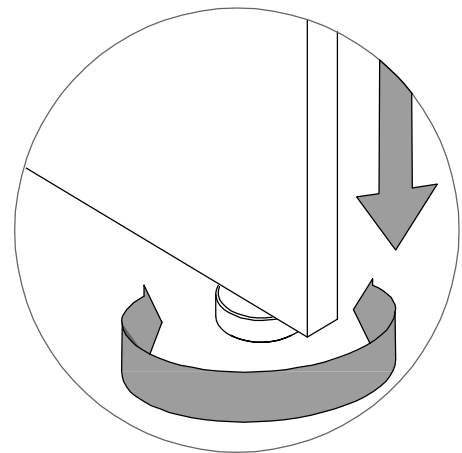

# STOCKHOLM

BY MARIO RUIZ, 2015

*punt*

**12** PLACE THE PLATE AND SCREW  
PLINTH TO THE SIDBOARD.  
COLOCAR PLETINAS Y ATORNILLAR  
EL ZÓCALO AL APARADOR.

**M**  
4 uds

70044  
M6X15

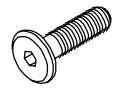

**E**

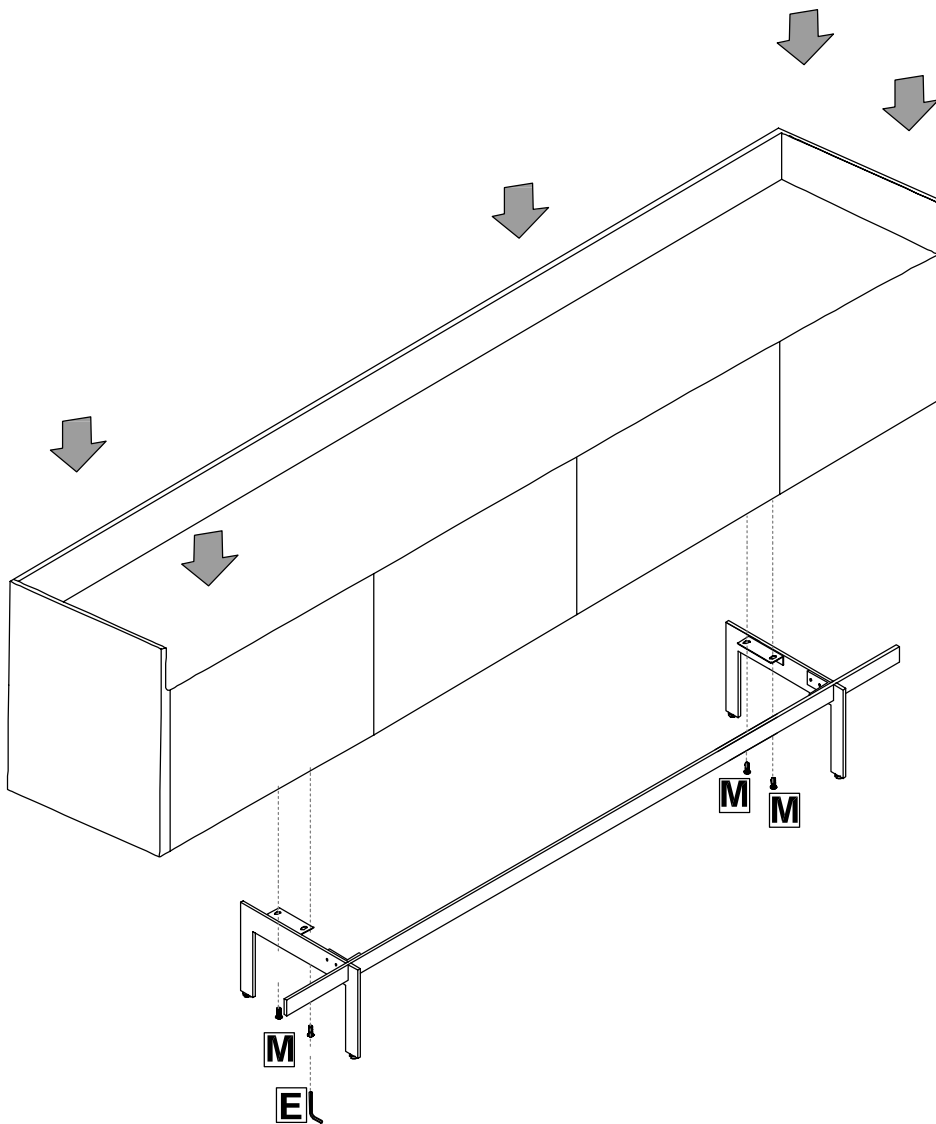
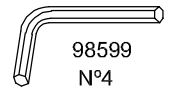

ONLY IF IT HAS DRAWERS  
SOLO SI LLEVA CAJONES

## 13A PLACE DRAWERS. COLOCAR CAJONES.

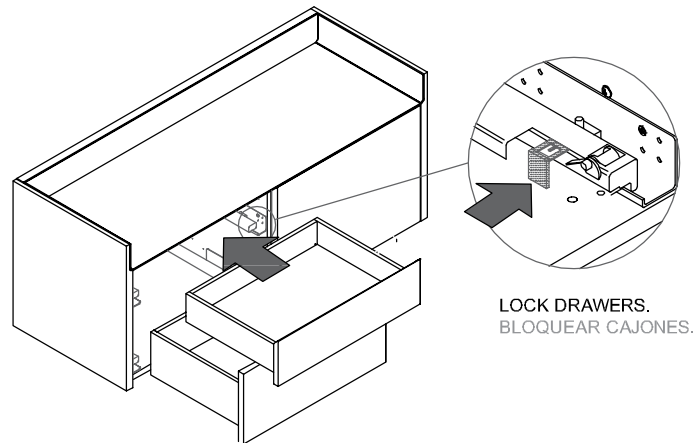

## DRAWER REGULATION REGULACIÓN CAJONES

### 13.1

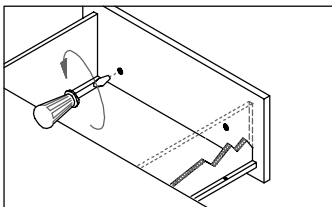

TURN BOTH SCREWS TO ADJUST  
THE DRAWER BORDER.  
GIRA AMBOS TORNILLOS PARA  
AJUSTAR LA FRONTERA DEL  
CAJÓN.

### 13.2

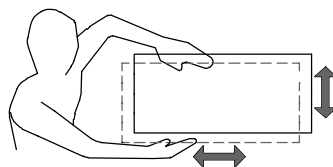

MOVE TO POSITION THE BORDER.  
MOVER PARA POSICIONAR LA  
FRONTERA.

### 13.3

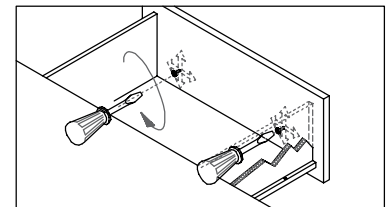

SCREW TO LOCK THE BORDER.  
ATORNILLAR PARA BLOQUEAR  
LA FRONTERA.

# DOOR ADJUSTMENT

LUCCA, FIRENZE, STOCKHOLM, MALMÖ, VELASCA

*punt*

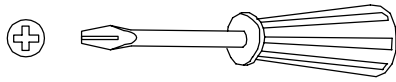

USE A PHILLIPS SCREWDRIVER FOR DOOR ADJUSTMENT.  
USAR DESTORNILLADOR DE ESTRELLA PARA LA REGULACIÓN DE PUERTAS.

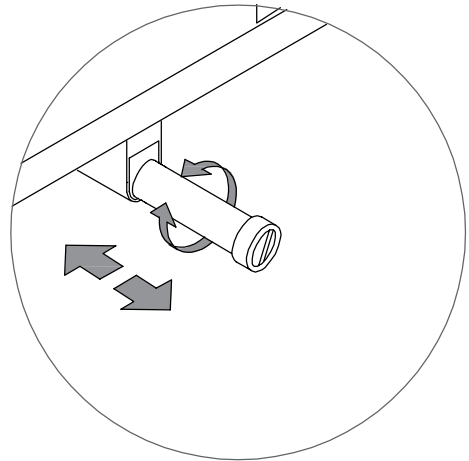

WITH THE EJECTOR OUT TO ROTATE TO INCREASE OR DECREASE ITS LENGTH.  
CON EL EXPULSOR FUERA GIRAR PARA AUMENTAR O DISMINUIR SU LARGO.

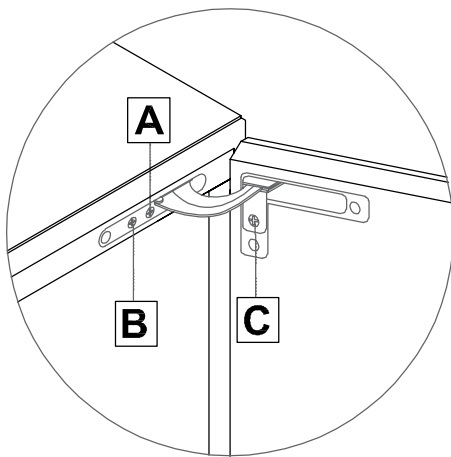

REGULAR BOTH AT THE TOP AND BOTTOM.  
REGULAR TANTO EN PARTE SUPERIOR COMO EN INFERIOR.

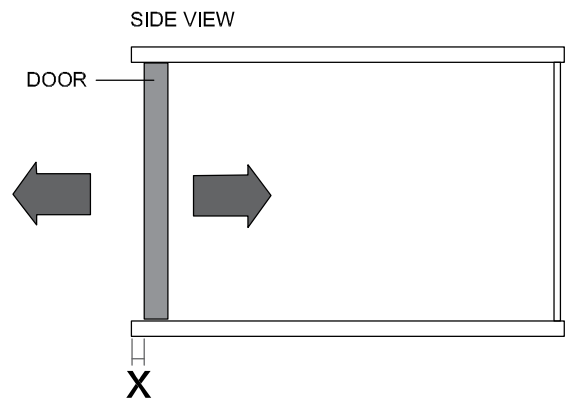

**A** MOVES THE DOOR IN AND OUT BY INCREASING OR DECREASING THE X-DISTANCE.  
METE Y SACA LA PUERTA AUMENTANDO O REDUCIENDO LA DISTANCIA EN X.

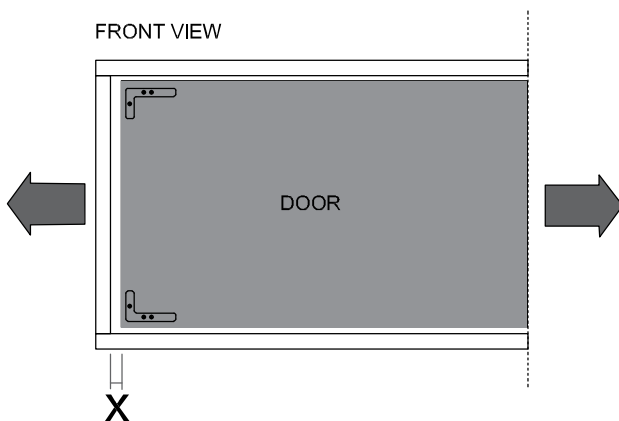

**B** MOVES THE DOOR CLOSER AND FURTHER AWAY BY INCREASING OR DECREASING THE X-DISTANCE.  
ACERCA Y ALEJA LA PUERTA AUMENTANDO O REDUCIENDO LA DISTANCIA EN X.

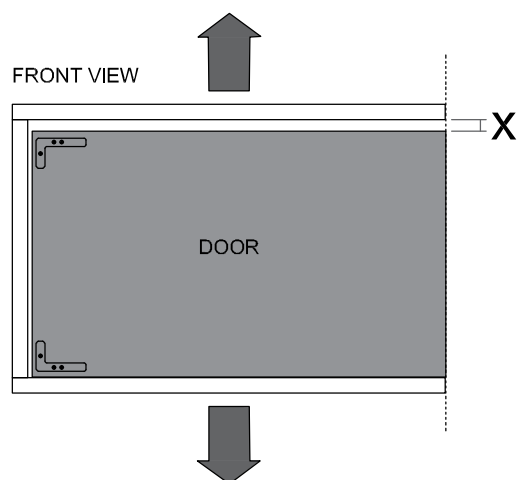

**C** RAISES AND LOWERS THE DOOR BY INCREASING OR DECREASING THE X-DISTANCE.  
SUBE Y BAJA LA PUERTA AUMENTANDO O REDUCIENDO LA DISTANCIA EN X.